

# KPAC-2

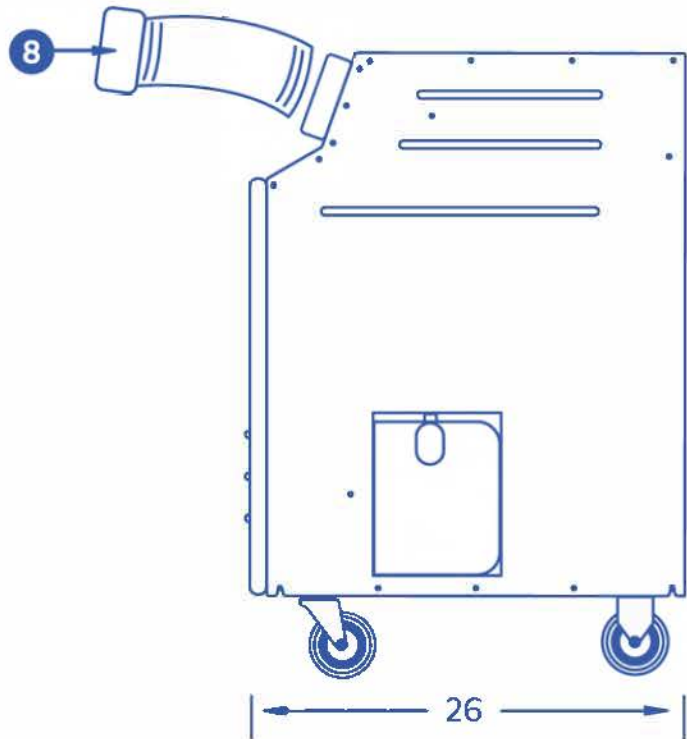

## KPAC 1811-2

- |                        |   |
|------------------------|---|
| 1) Cold Air Return     | 5) Condensate Air Outlet                  |
| 2) Control Pad         | 6) Power Cord                             |
| 3) Cold Air Supply     | 7) Condensate Tank                        |
| 4) Condenser Air Inlet | 8) Air Chutes (Attach To Cold Air Supply) |

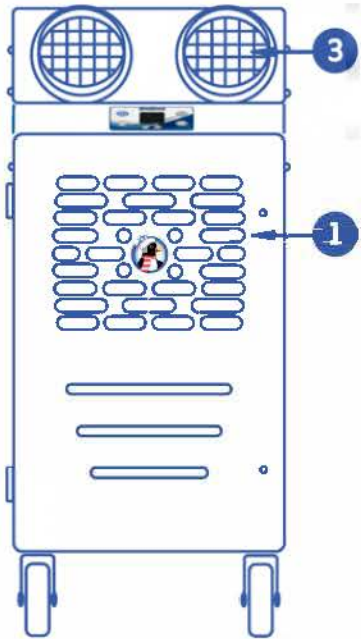
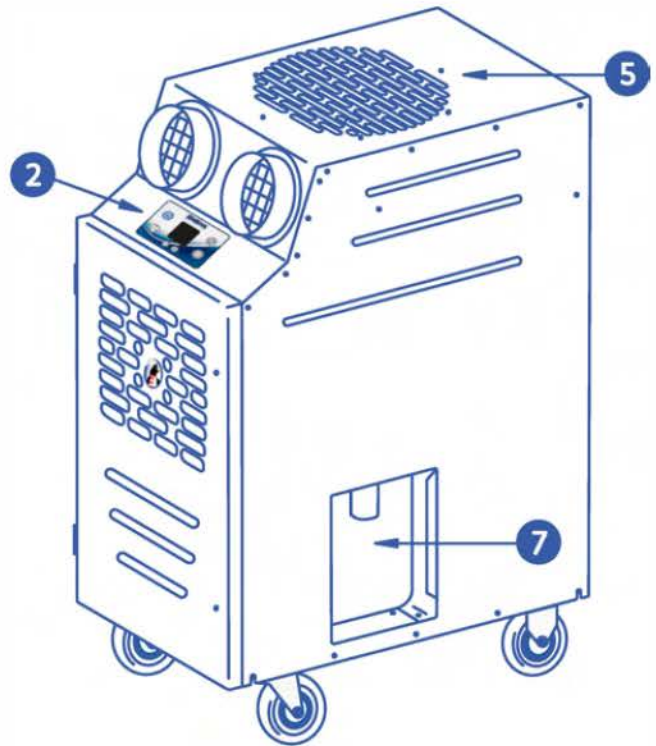
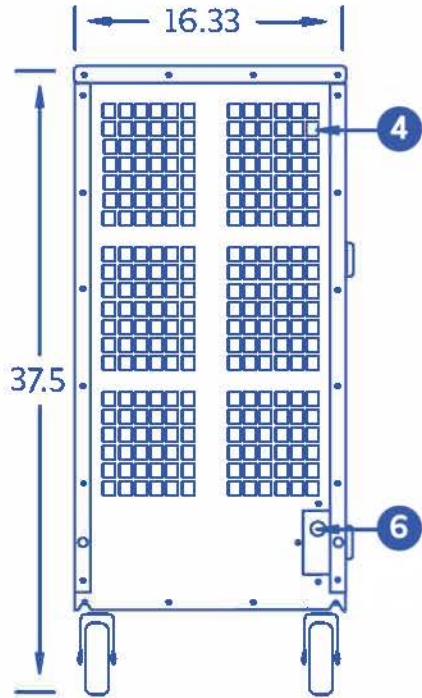

ETL LISTED CONFORMS TO ANSI/UL1995  
CERTIFIED TO CAN/CSA 22.2 NO 235

[portableairgroup.com](http://portableairgroup.com)

# KPAC-2



## KPAC 1811-2 AIR COOLED PORTABLE

### COOLING CAPACITY

BTU/hr @95 F at 60%RH	16,800 / 1.5-Ton
-----------------------	------------------

### COMPRESSOR DATA

Compressor Type	Hermetic Rotary
Operating Temperatures	70-105°F 50% RH
Non-CFC Refrigerant	410A

### FAN DATA EVAPORATOR

Fan Type (Centrifugal)	Direct Drive
Air Flow (CFM)	625 / Single Speed
Supply Air Control	Adjustable Vent
Supply Air Chute	2 - 5" dia x 16'

### CONDENSER WATER FLOW

Fan Type (Centrifugal)	Direct Drive
Air Flow (CFM)	700
Condenser Duct Specs (optional)	1 - 12" Dia. x 8' length
Condenser Duct Max Length	25'

### ELECTRICAL DATA

Power Supply	115 V / Single Phase
Current Consumption	15.2 Amps
Power Consumption	1.57 kW
Maximum Circuit Breaker	30 Amps
Recommended Breaker Size	20
Minimum Circuit Ampacity	19.7 Amps
Min/Max Voltage	105 - 125
Power Cord Gauge / Length in Feet	12 AWG / 8'
Plug Configuration	NEMA 5 - 20

### DIMENSIONAL DATA

Width x Length x Height	16.325" x 26" x 37.75"
Weight	157 lbs.
Shipping Weight	207 lbs.
Ceiling Kit	22 lbs.
Shipping Weight W/ Ceiling Kit	229 lbs.

### SAFETY DEVICE DATA

Compressor Overload	Internal
Fan Motor Overload	Automatic Internal
Evaporator Freeze Guard	Freeze Stat
High Pressure Switch	Manual
Low Pressure Switch	Auto
Compressor Short Cycle	Yes
Automatic Restart	Yes
Thermostat Type	Digital Microprocessor
Condensate Pump Overflow	Optional
Condensate Tank Overflow	Yes



Portable Air Group

Office: 1.919.240.5930  
Toll-free: 1.866.948.5300  
Fax: 1.866.948.5400  
Web: [portableairgroup.com](http://portableairgroup.com)