

# SPECIFICATIONS

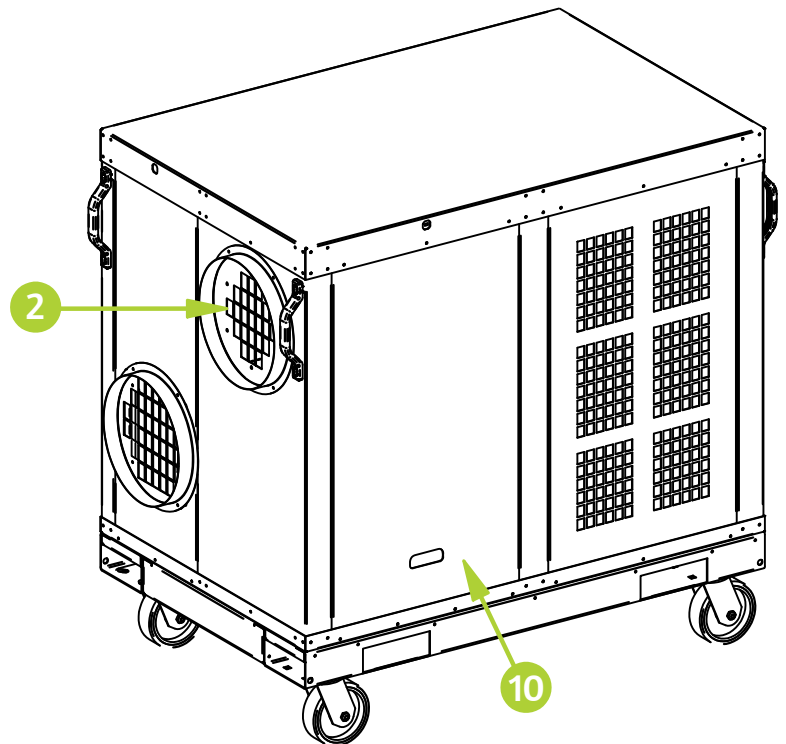

# KPO5-21

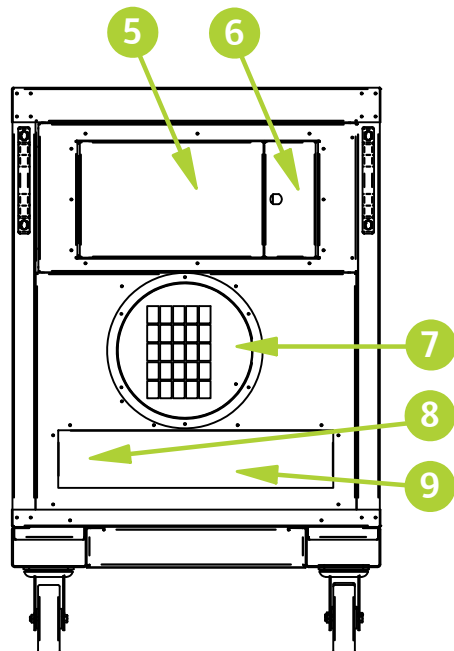
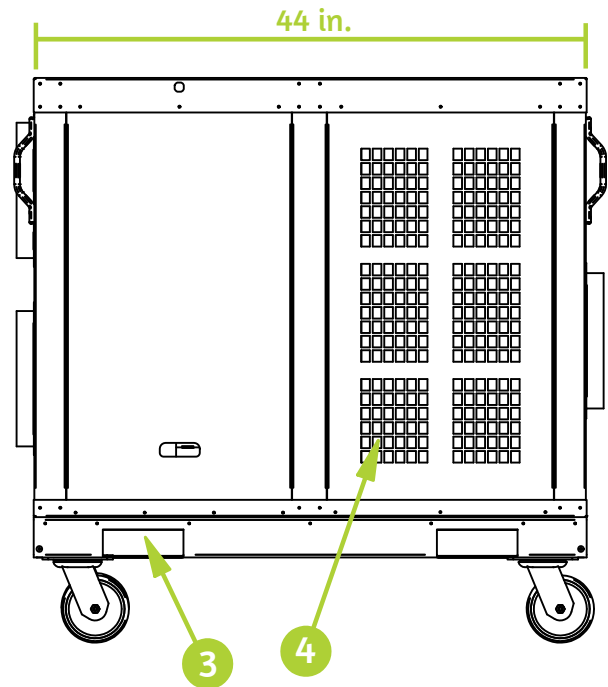
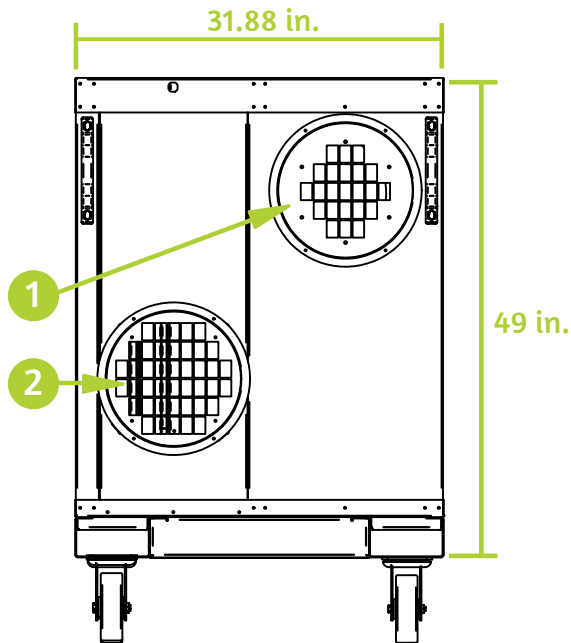

## KPO5-21

- 1. Cold Air Supply
- 2. Cold Air Return
- 3. Fork Pocket
- 4. Condenser Air Inlet
- 5. Electrical Panel
- 6. Control Panel Access
- 7. Condenser Air Outlet
- 8. Condensate Nipple
- 9. Power Cord
- 10. Access Panel



# SPECIFICATIONS



# KPO5-21

## COOLING CAPACITY

BTU/hr @ 95F at 60% RH	60,000 (5 Ton)
Operating Temperatures	30 - 110 F 50%RH

## HEATING OPTION

Heat Strips / BTU	12kW / 41,600
-------------------	---------------

## COMPRESSOR DATA

Compressor Type	Scroll
Refrigerant	407C

## FAN DATA

### EVAPORATOR

Fan Type (Centrifugal)	Hyperdrive
Air Flow	2,400 CFM
Supply and Return Air Device	1 - 12" flanges for supply and 1 - 12" for return
Maximum Duct length	50 Ft. total for supply and return

### CONDENSER

Fan Type (Centrifugal)	Direct Drive
Air Flow	3500 CFM
Condenser Exhaust flange	12"
Condenser Duct Max. Length	65 Ft.
Condenser fan speed control	Variable Frequency Drive

## ELECTRICAL DATA

Power Supply	208V / 230V Single Phase
Current Consumption	39.1 amps
Power Consumption	7.23 kWh
Maximum Circuit Breaker	50 amps
Minimum Circuit Ampacity	45.5 amps
Min./Max. Voltage	195 - 250
Power Cord Gauge/Length	8 AWG/10 Ft.
Optional Camlocks	Color Coded Male Camlocks

## CONSTRUCTION

Skid	12 Gauge G90 Galvanized Steel / Epoxy Powdercoat
Cabinet	16 Gauge G90 Galvanized Steel / Epoxy Powdercoat
Casters	6" Heavy Duty Swivel and Locking

## DIMENSIONAL DATA

Width x Depth x Height	32" x 48" x 49" with 6" Wheels
Weight	670 Lbs.
Shipping Weight	735 Lbs.

## SAFETY DEVICE DATA

Compressor Overload	Internal
Fan Motor Overload	Automatic Internal
Evaporator Freeze Protection	Hot Gas Bypass with variable fan speed control
High Pressure Switch	Manual
Low Pressure Switch	Automatic
Compressor Short Cycle	Yes
Automatic Restart	Yes
Thermostat Type	Digital
Condensate Pump Overflow	Yes
Internal Condensate Pump (high lift)	Yes