

SPECIFICATIONS

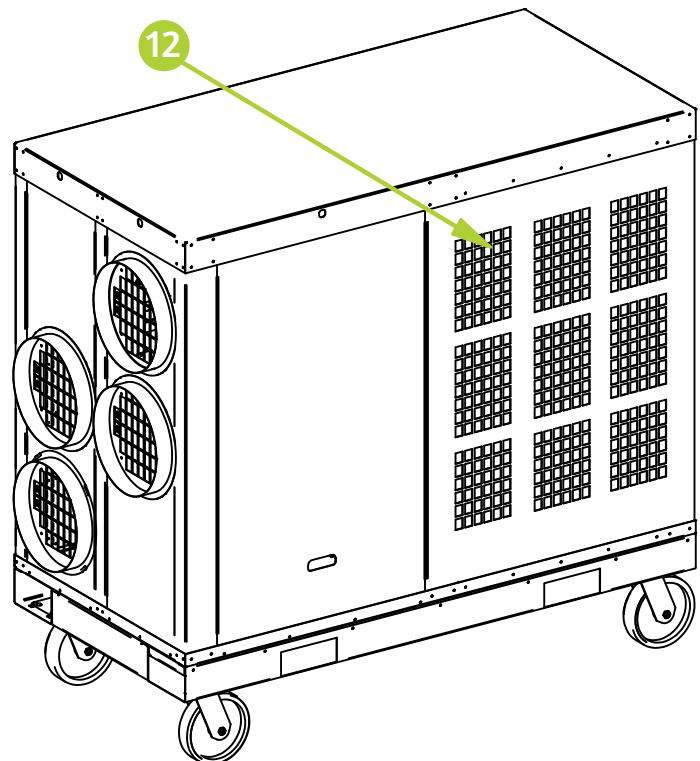

KPO12-23

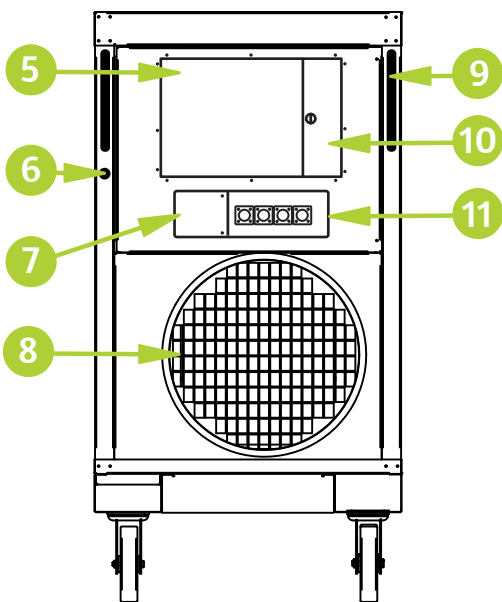
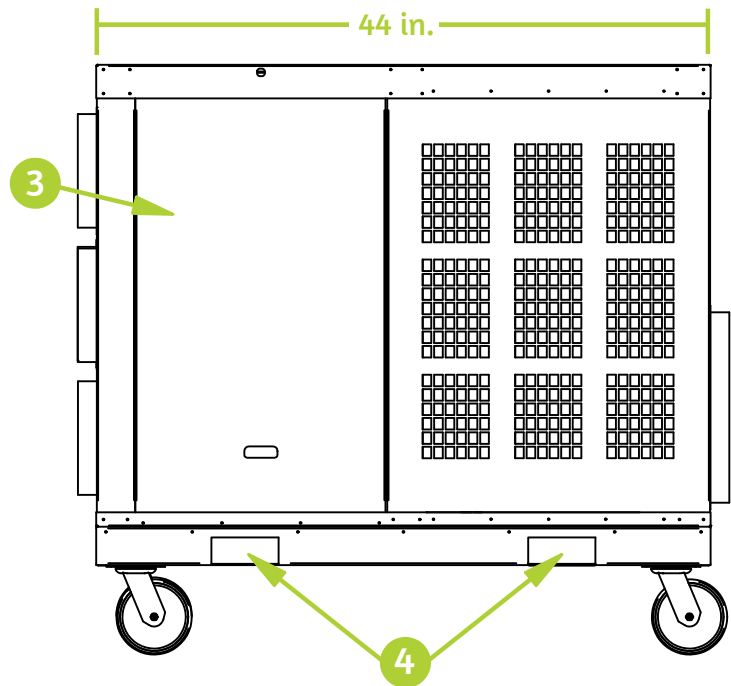
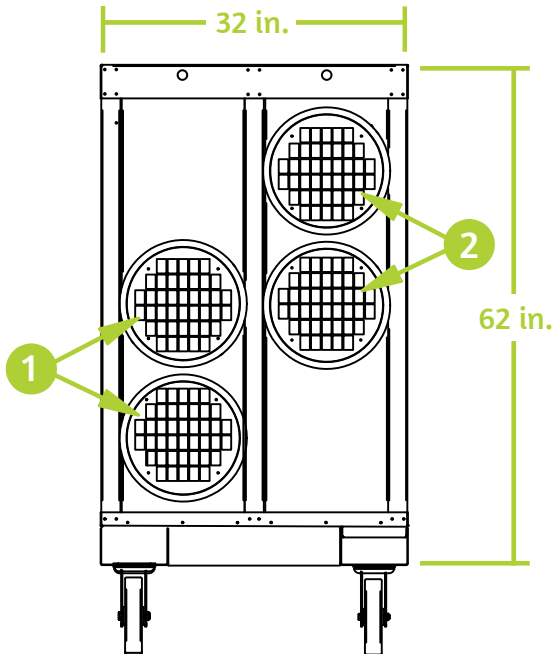

KPO12-23

- 1. Cold Air Return
- 2. Cold Air Supply
- 3. Access Door
- 4. Forklift Pockets
- 5. Electrical Panel
- 6. Condensate Nipple
- 7. Breaker Access
- 8. Condenser Air Outlet
- 9. Handle
- 10. Control Panel Access
- 11. Camlock Connections
- 12. Condenser Air Inlet



ETL LISTED CONFORMS TO ANSII/UL995
CERTIFIED TO CAN/CSA 22.2 NO 235

SPECIFICATIONS



KPO12-23

COOLING CAPACITY

BTU/hr @ 95F at 60% RH	135,000 (12 Ton)
Operating Temperatures	30 - 110 F 50%RH

HEATING OPTION

Heat Strips / BTU	24kW / 83,300
-------------------	---------------

COMPRESSOR DATA

Compressor Type	Scroll
Refrigerant	407C

FAN DATA

EVAPORATOR

Fan Type (Centrifugal)	Hyperdrivex X2
Air Flow	5,500 CFM
Supply and Return Air Device	2 - 12" flanges for supply and 2 - 12" for return
Maximum Duct length	75 Ft. each for supply and return

CONDENSER

Fan Type (Centrifugal)	Belt Drive
Air Flow	8500 CFM
Condenser Exhaust flange	20"
Condenser Duct Max Length	100"
Condenser fan speed control	Variable Frequency Drive

ELECTRICAL DATA

Power Supply	208V / 230V Three Phase
Current Consumption	56.9 amps
Power Consumption	22.88 kWh
Maximum Circuit Breaker	100 amps
Recommended Breaker Size	80 amps
Minimum Circuit Ampacity	71.225 amps
Min./Max. Voltage	195 - 250
Power Quality Control	Internal Phase and Power Monitor
Power Connection	Color Coded Male Camlocks

CONSTRUCTION

Skid	12 Gauge G90 Galvanized Steel / Epoxy Powdercoat
Cabinet	16 Gauge G90 Galvanized Steel / Epoxy Powdercoat
Casters	8" Heavy Duty Swivel / Locking

DIMENSIONAL DATA

Width x Depth x Height	32" x 64" x 60" with 8" Casters
Weight	1080 Lbs.
Shipping Weight	1180 Lbs.

SAFETY DEVICE DATA

Compressor Overload	Internal
Fan Motor Overload	Automatic Internal
Evaporator Freeze Protection	Hot gas bypass with variable fan speed control
High Pressure Switch	Manual
Low Pressure Switch	Automatic
Compressor Short Cycle	Yes
Automatic Restart	Yes
Thermostat Type	Digital
Condensate Pump Overflow	Yes
Internal Condensate Pump (high lift)	Yes