



SPECIFICATIONS

KIB1811

COOLING CAPACITY	BTU/hr @ 95F at 60% RH	17,700 (1.1-Ton)
COMPRESSOR DATA	Compressor Type	Hermetic Rotary
	Operating Temperatures	60-110 F 50%RH
	Refrigerant	410A
FAN DATA Evaporator	Fan Type (Centrifugal)	Direct Drive
	Air Flow (CFM)	625/3 Speed
	Supply Air Device	Adjustable Vent
	Supply Air Chute Kit (optional)	2 - 5" Dia. x 16" Length
Condenser	I/O Integral Condenser	Balanced Air Flow
	Fan Type (Centrifugal)	Direct Drive
	Air Flow (CFM)	950
	Condenser Duct Specs (optional)	2 - 12" Dia. x 8' Length
	Condenser Duct Max. Length	25'
ELECTRICAL DATA	Power Supply (Volts)	115/Single Phase
	Current Consumption (Amps)	15.4
	Power Consumption (Watts)	1.4
	Maximum Circuit Breaker (Amps)	20
	Recommended Breaker Size	21.725
	Minimum Circuit Ampacity(Amps)	19.575
	Min./Max. Voltage	105-125
	Power Cord Gauge/Length	14/6'
	Plug Configuration	NEMA 5-20
DIMENSIONAL DATA	Width x Depth x Height (Inches)	16.325" x 36" x 37.25"
	Weight (Lbs.)	205
	Shipping Weight (Lbs.)	255
	Ceiling Kit Weight (Lbs.)	38
	Shipping Weight w/ Ceiling Kit	293
SAFETY DEVICE DATA	Compressor Overload	Internal
	Fan Motor Overload	Automatic Internal
	Evaporator Freeze Protection	Hot Gas Bypass
	High Pressure Switch	Manual
	Low Pressure Switch	Automatic
	Compressor Short Cycle	Yes
	Automatic Restart	Yes
	Thermostat Type	Microprocessor/Digital
	Condensate Pump Overflow	Yes
	Condensate Tank Overflow	Yes



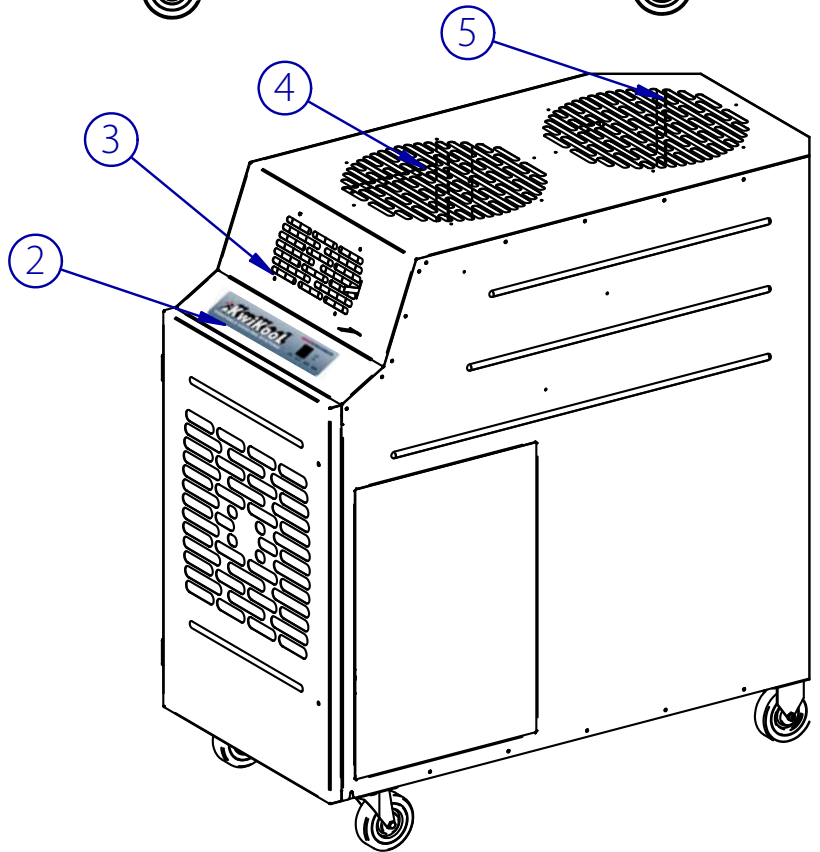
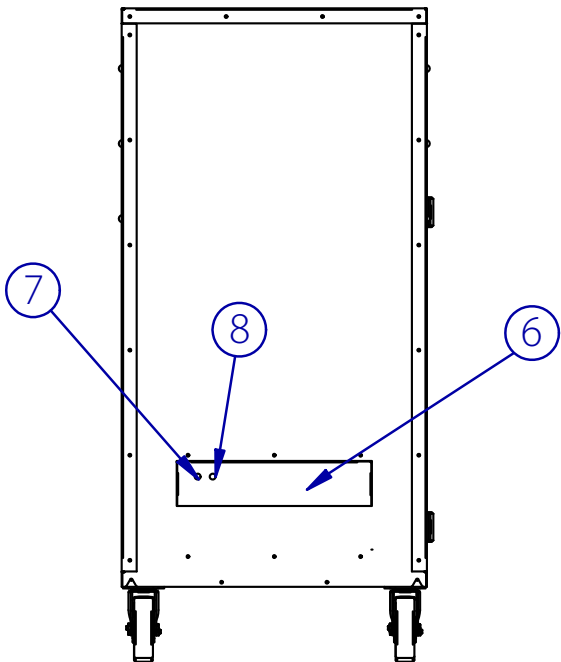
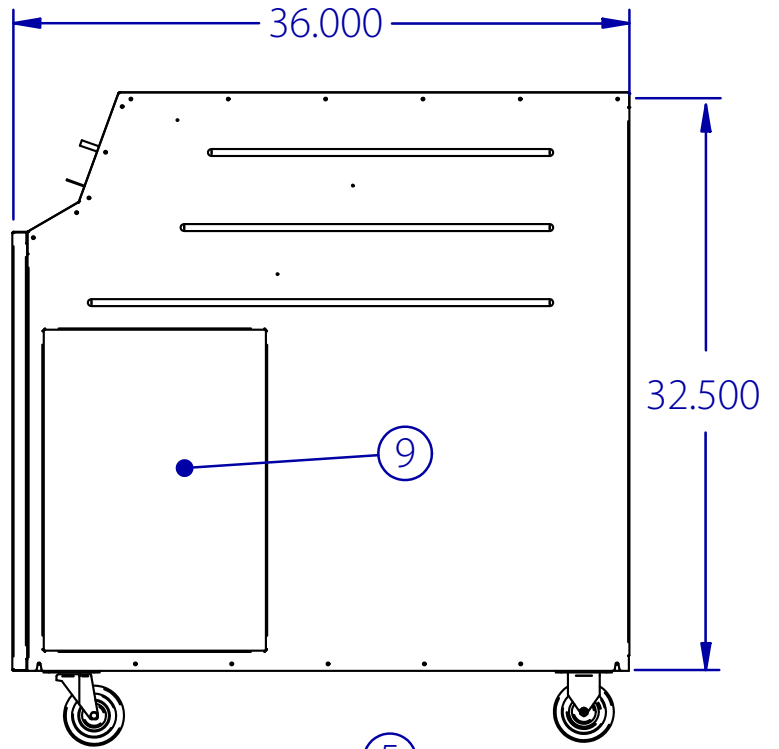
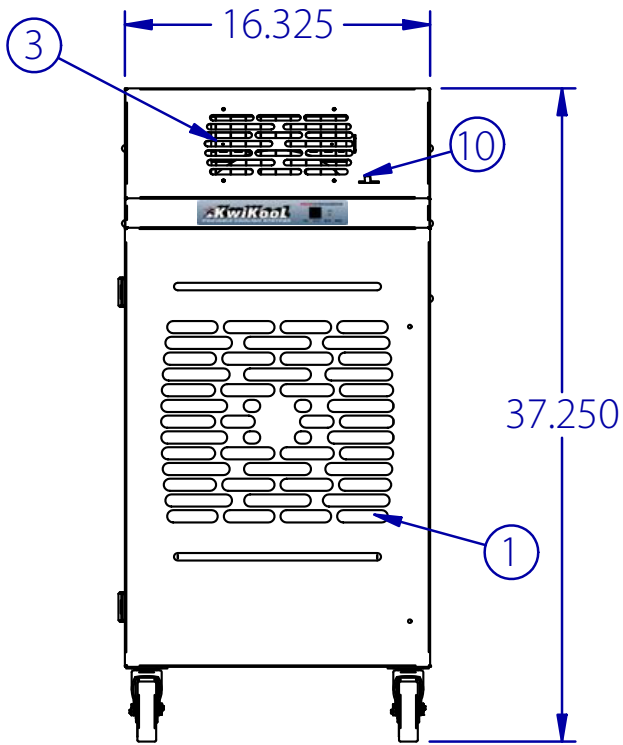

KIB 1811

LEGEND

- | | |
|-------------------------|--------------------------|
| 1. Cold Air Return | 6. Power Cord Storage |
| 2. Control Pad | 7. Condensate Nipple |
| 3. Cold Air Supply | 8. Condensate Alarm Jack |
| 4. Condenser Air Inlet | 9. Access Door |
| 5. Condenser Air Outlet | 10. Vent Control |



ETL LISTED CONFORMS TO ANSI/UL1995
CERTIFIED TO CAN/CSA 22.2 NO 235